

MOBA



FARMPACKER



FARMPACKER

MOPACK 100

A complete process overview from your working position

All technology accessible by opening one cover



The Farmpacker for your profit

Mopack Farmpackers are designed for your profit. High performance machines with net capacities close to the theoretical maximum coupled with well built robust designs. Their low-maintenance technology with their hygienic and easy to clean construction makes these Farmpackers reliable and hard working companions for many years to come.

Concept

A fundamental principle of Mopack is “individual egg handling”. Many farm packer concepts wait until there is one row of 6 eggs complete directly coming from an accumulator. Only then, the packer makes a movement, receives these eggs and in the same time places 6 previously fetched eggs in a tray. But when one egg is missing or in one channel there is not enough pressure to push this 6th egg forward, the other 5 eggs will have to wait and the whole farm packer process stands idle.

Not in Mopack. Eggs are accumulated and put on rollers independent of the packing process and if one egg is missing in the flow, it is only this single egg and thanks to the track (or carrousel) function, the rest of the process continues. The loss of efficiency is limited to fractions of a second. The result of this concept is a much better performance and a net production that is very close to the theoretical maximum capacity.

There are hardly any reasons for stopping; the well known and reliable Moba denester ensures the correct handling of all known tray types.

User controls

Since the controls are handled by a robust industrial system, simple on and off buttons do the job. However, a counting system is available that can even handle several chicken-houses independently. Several simple functions can be chosen from a simple LCD touch screen menu. The result: advanced technical functions combined with pure simplicity.

Inkjet

Another strict advantage of the Mopack concept is the seamless integration possibility for continuous inkjet system. Since continuous inkjet systems are more suitable for rough industrial purposes than drop-on-demand systems, many customers look for a farm packer where a single headed industrial no maintenance type can be fitted. Mopack offers the ideal basis for this.

Perfect inkjet possibilities on top of eggs

Versatile conveying systems to adapt to your needs, with a minimum of supporting legs on the floor.

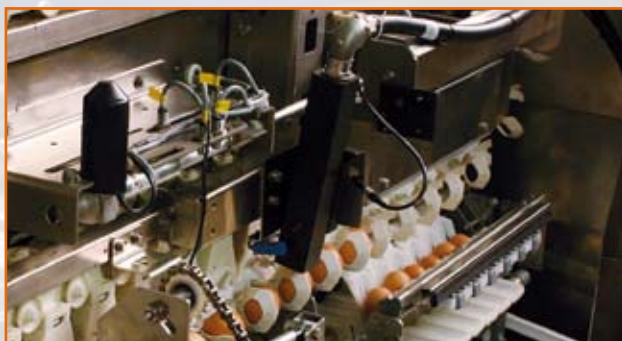

Construction

The complete construction is easy to clean and is made of stainless steel and Moba's well known plastic parts take care of gentle and hygienic egg handling all technical spin-offs of the experiences in Moba's egg graders. Mopack has a vertical track system. This high tech track system has some strict advantages:

- Eggs are only travelling a straight trajectory without any curves to make sure no unnecessary forces are applied to the eggs. The dimensions are arranged in such a way that the forward speed is as low as possible but combined with a high output capacity.
- All constructions are placed as much as possible above the egg flow and the grippers are constructed in such a way that accumulation of dirt and egg liquids is kept to the absolute minimum.
- The complete egg handling process including infeed, transfer, inkjet and dropping mechanism is very easy accessible for cleaning and maintenance (if any) by opening one single cover.
- This cover is made of semi transparent material so that from your working position, the whole process is able to be visually monitored.

- The frame holding this track is only 65cm wide and combined with smart logistics, this results in an efficient floor plan for your packing room.
- Very few legs on the floor, a quick installation time and elimination of critical adjustment procedures are the benefits of combining all relevant process steps in to this single "main frame" construction.

Mopack's can be delivered in left and right handed configurations. The output conveyors are standardized to fit on to Traystackers and Traypalletisers. Curves and extensions can be made to your individual requirements.

Specifications

MOPACK 100	100 cases/hour = 36,000 eggs/hour
Voltage	200-230 Volt or 380-415 Volt, 3 Phase + o
Power consumption	2,5 KVA (without traystacker)
Dimensions	See drawing; total dimensions depending on configuration

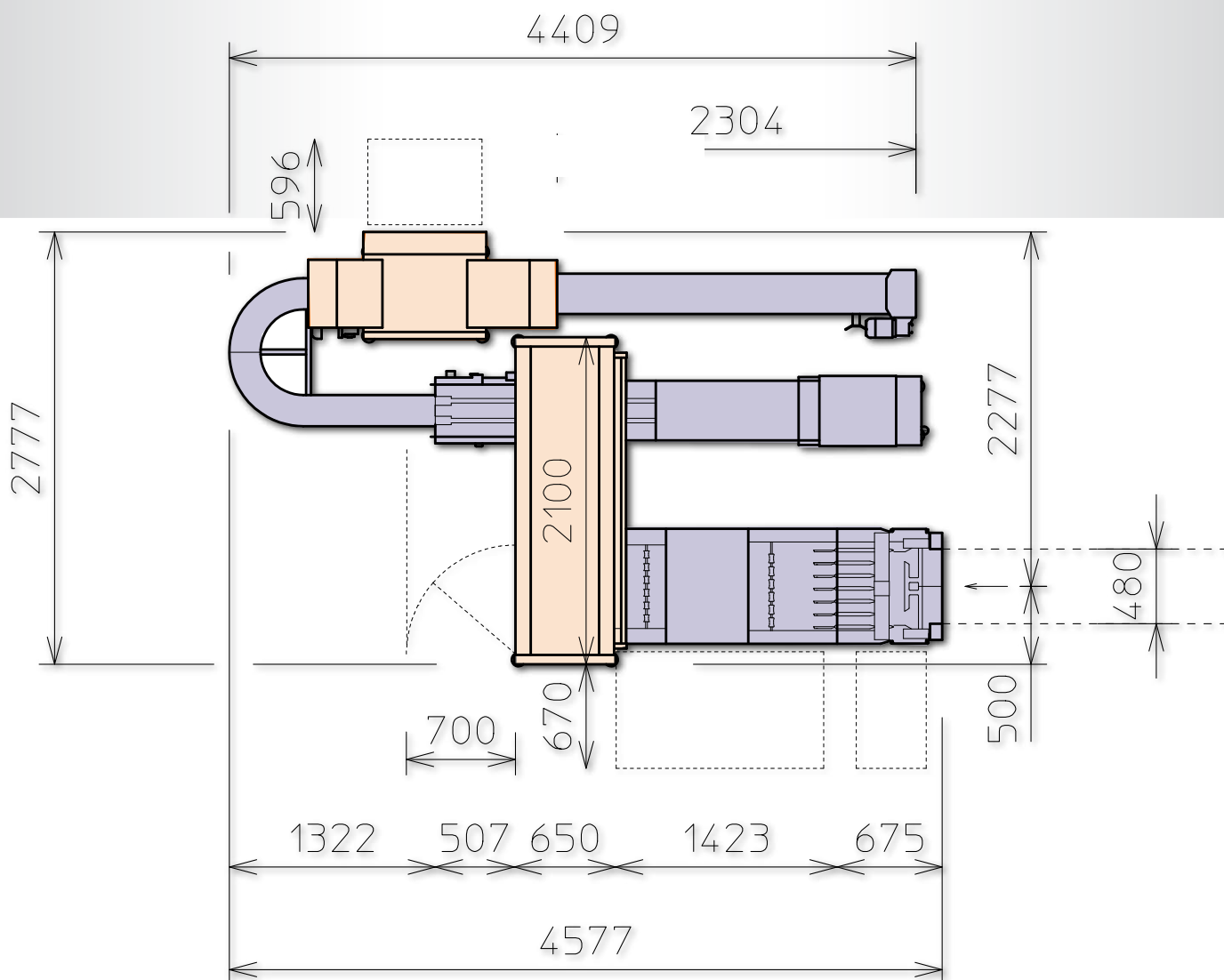

THE PARTNER FOR PROFIT

Moba B.V. (Headoffice)

P.O. Box 7, 3770 AA Barneveld • Stationsweg 117, The Netherlands • T: +31 (0) 342 455 655 • F: +31 (0) 342 455 634 • E: sales@moba.nl

For worldwide offices and agents' network, please look at www.moba.nl